

PALMER TOWNSHIP, PENNSYLVANIA



Swimming Pool & Barrier Details

Based on the 2015 International Residential Code

(Designed and Printed March 2020)



CONTENTS

General Information.....	2	In-Ground Swimming Pools.....	6
Barrier Requirements.....	2	Permanent Spas & Exercise Spas.....	7
Decks.....	5	Portable Spas & Exercise Spas.....	8
Suction Entrapment Avoidance.....	6	Permit Application Information.....	9
On-Ground Storable (Permanent or.....	6	Pool Deck Access Gate Sample Details.....	11
Portable) Swimming Pools		Application Checklist	12

THE INFORMATION CONTAINED IN THIS DOCUMENT REPRESENTS ONLY A PORTION OF CODE-RELATED REQUIREMENTS AND IS NOT A COMPLETE OR EXHAUSTIVE LIST – REFER TO THE ACTUAL CODE PRINTING. ALL RESIDENTIAL POOLS, SPAS AND ASSOCIATED BARRIERS MUST BE CONSTRUCTED IN CONFORMANCE WITH THE 2015 INTERNATIONAL RESIDENTIAL CODE (IRC) AND THE 2015 INTERNATIONAL SWIMMING POOL & SPA CODE (ISpsc), WHICH SUPERCEDES ANY DISPREPANCY LOCATED HEREIN. APPLICABLE 2015 ISpsc CITATIONS REFERENCED IN BRACKETS.

GENERAL INFORMATION

1. Definition: Barrier – A permanent fence, wall, building wall, or combination thereof that completely surrounds the pool or spa and obstructs the access to the pool or spa. The term "permanent" shall mean not being able to be removed, lifted, or relocated without the use of a tool.
2. During the construction of the pool, orange construction fence must be placed to prevent access to the pool. All fences shall be at least 48" tall and provide enough strength to resist a 200-pound force per square foot. [
3. Pools may not be filled with water until the permanent barriers are installed.
4. The following inspections are required:
 - Framing of Walls (In-ground Pools Only)
 - Rough Plumbing (In-ground Pools Only)
 - Mechanical – Gas (In-ground Pools Only)
 - Electrical – Equipotential Plane, Trench, Bonding, Final
 - Final
5. It shall be the duty of the permit holder or their agent to notify the building official that such work is ready for inspection. It shall be the duty of the person requesting any inspections required by this code to provide access and means for inspection of such work.
6. All inspections must be made at least 24 hours in advance. All construction documents shall be on the jobsite and provided to inspector upon request. You may schedule an appointment for inspection by calling Palmer Township's Offices at (610) 253-7191 Monday thru Friday 8:30a.m. – 4:30p.m.
 - NOTE: INSPECTIONS ARE MANDATORY BY LAW. FAILURE TO OBTAIN THE INSPECTIONS MAY CAUSE VIOLATIONS AND FINES.

Scope

The provisions of the 2015 International Swimming Pool & Spa Code shall apply to the construction, alteration, movement, renovation, replacement, repair and maintenance of aquatic recreation facilities, pools and spas. The pools and spas covered by this code are either permanent or temporary and shall be only those that are designed and manufactured to be connected to a circulation system and that are intended for swimming, bathing or wading.

Electrical Requirements

Electrical installations and/or alterations shall comply with the 2015 International Residential Code and NFPA 70, were referenced. [302.1]

Plumbing Requirements

Pipe, fittings and components shall be listed in accordance with NSF 50 or NSF 14. [302.3] Backflow protection shall be installed for water supplies to pools and spas. [302.4]

Energy Requirements

The electric power to heaters to pools and permanent spas shall be controlled by a readily accessible on-off switch. Gas-fired heaters shall not be equipped with a continuously burning pilot light. [303.1.1] Heaters and pump motors shall have time switches or other control methods which can automatically turn on and off heaters and motors according to a preset schedule. [303.1.2] Outdoor heated pools and permanent spas shall be provided with a vapor-retardant cover. [303.1.3]

Barrier Requirements

The provisions of Section 305, of the 2015 International Swimming Pool & Spa Code, shall apply to the design of barriers for pools and spas and are intended to prevent potential drowning and near drowning through the use of physical barriers and warning devices. [305.1]

Exceptions:

- Lockable safety cover which complies with ASTM F 1346 for hot tubs and spas.
- Powered safety cover which complies with ASTM F 1346 for swimming pools.

Outdoor swimming pools and spas and indoor pools shall be surrounded by a barrier that complies with the following [305.2]:

- The top of the barrier shall be at least 48 inches above grade measured on the side of the barrier which faces away from the swimming pool.
- Such height shall be maintained around the entire perimeter of the pool for a distance of 3-feet, measured horizontally from the outside of the barrier.
- The maximum vertical clearance between grade and the bottom of the barrier shall be 2 inches for non-solid surfaces and 4-inches for solid surfaces measured on the side of the barrier which faces away from the swimming pool.
- Where the top of the pool structure is above grade, such as an above-ground pool, the barrier may be at ground level, such as the pool structure, or mounted on top of the pool structure. Where the barrier is mounted on top of the pool structure, the maximum vertical clearance between the top of the pool structure and the bottom of the barrier shall be 4 inches.
- Openings in the barrier shall not allow passage of a 4-inch-diameter sphere. [305.2.2]
- Solid barriers which do not have openings, such as a masonry or stone wall, shall not contain indentations or protrusions except for normal construction tolerances and tooled masonry joints. [305.2.3]

Mesh Fence (other than a chain link fence) [305.2.4]:

1. Shall be installed in accordance with the manufacturer's installations instructions.
2. Bottom of mesh fence shall not be more than 1-inch above deck, installed surface or grade.
3. Maximum vertical clearance from bottom of mesh fence and the solid surface shall not allow the fence to be lifted more than 4-inches from the decking or grade.
4. The fence shall be constructed so as to not allow the passage of a 4-inch sphere.
5. An attachment device, such as a hook-and-eye type latch incorporating a spring-actuated retaining lever, shall attach each mesh panel and be located not less than 45-inches above grade.
6. Hinged gates shall meet the requirements of the "Gates" Section R305.3.
7. Any patio deck sleeves shall be of a nonconductive material.
8. Mesh fences are prohibited from being install on top of on-ground residential pools.

Closely Spaced Horizontal Members [305.2.5]:

1. Where the barrier is composed of horizontal and vertical members and the distance between the tops of the horizontal members is less than 45 inches, the horizontal members shall be located on the swimming pool side of the fence. Spacing between vertical members shall not exceed 1 ¾ inches in width. Where there are decorative cutouts within vertical members, spacing within the cutouts shall not exceed 1 ¾ inches in width.

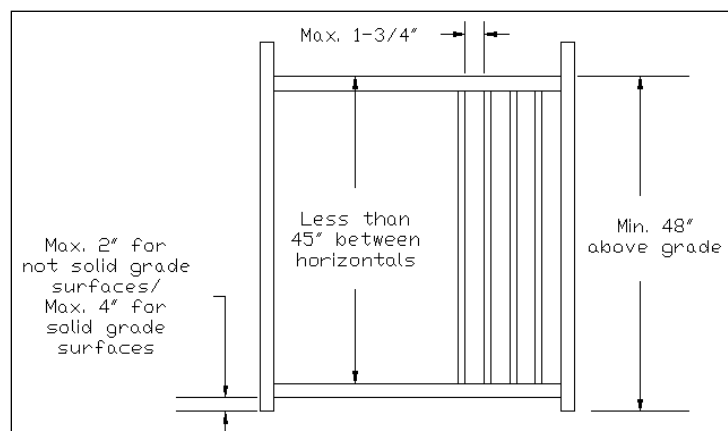

Widely Spaced Horizontal Members [305.2.6]:

1. Where the barrier is composed of horizontal and vertical members and the distance between the tops and the horizontal members in 45 inches or more, spacing between vertical members shall not exceed 4 inches. Where there are decorative cutouts within vertical members, spacing within the cutouts shall not exceed 1 ¾ inches in width. [305.2.6]

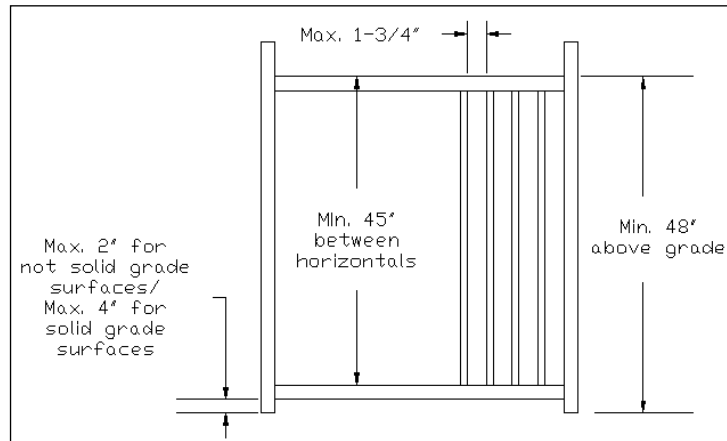

Chain Link Dimensions [305.2.7]:

1. The maximum opening formed by a chain link fence, or by use of slats fastened at the top and bottom to reduce openings, shall not be more than 1-¾ inches.

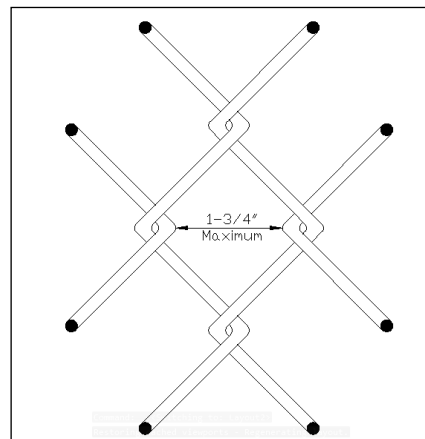

Diagonal Members [305.2.8]:

1. Where the barrier is composed of diagonal members, such as lattice fence, the maximum opening formed by the diagonal members shall not be greater than 1 ¾ inches. The angle, from vertical, shall not be greater than 45-degrees.

Clear Zone [305.2.9]:

1. A clear zone, of not less than 36-inches measured between the exterior of the barrier and any permanent structures or equipment, shall be maintained.

Poolside Barrier Setbacks [305.2.10]:

1. The water's edge shall be a minimum of 20-inches from the pool or spa side of the required barrier.

Gates [305.3]:

Access gates shall comply with the requirements above and shall be equipped to accommodate a locking device. Pedestrian access gates shall open outward away from the pool and shall be self-closing and have a self-latching device. Gates other than pedestrian access gates shall remain locked when not in use. [305.3.1] Where the release mechanism of the self-latching device is located less than

54 inches from the bottom of the gate, the release mechanism and openings shall comply with the following [305.3.3]:

1. The release mechanism shall be located on the pool side of the gate at least 3 inches below the top of the gate; and
2. The gate and barrier shall have no openings larger than ½ inch within 18 inches of the release mechanism.

Structure Wall as a Barrier [305.4]:

Where the wall of a dwelling or structure serves as part of the barrier and where doors or windows provide direct access to the pool or spa through that wall, one of the following conditions shall be met:

1. Operable windows having a sill height less than 48-inches above the indoor finished floor and doors shall have an alarm which is listed in accordance with UL 2017. Such alarm deactivation switches shall be located a minimum of 54-inches above the finished floor; or
2. The pool and/or spa shall be equipped with a safety cover in compliance with ASTM F 1346; or
3. Other means of protection, such as self-closing doors with self-latching devices, which are approved by the governing body, shall be accepted so long as the degree of protection afforded is not less than the protection afforded above.

On-Ground Pool Structure as a Barrier [305.5]:

Where an on-ground pool wall structure, or a barrier mounted on top such pool structure, shall be deemed to serve as a barrier provided it meets all of the following conditions:

1. Where only the pool wall serves as the barrier, it shall be a minimum of 48-inches above grade, the wall complies with the barrier requirements of Section 305.2 and the pool manufacturer allows the use of the wall to serve as such a barrier.
2. Where a barrier is mounted on top of the pool, the top of the barrier shall not be less than 48-inches above grade, be installed in accordance with the pool manufacturer's instructions, and the pool and barrier shall comply with the barrier requirements of Section 305.2.
3. The ladder or steps shall be capable of being secured, locked or removed to prevent access.
4. Any openings created by locking, securing or removing the ladder or steps do not allow the passage of a 4-inch sphere.

Decks

Decks, patios and similar surfaces (specifically constructed for sitting, standing or walking) installed immediately adjacent to or attached to the pool or spa shall be designed and constructed in accordance with the 2015 International Residential Code (IRC), except as provided in Section 306 of the 2015 International Swimming Pool & Spa Code (ISPSC).

Slip Resistant [306.2]:

Decks, ramps, coping and similar step surfaces as well as markers and insignias shall be slip resistant.

Slope [306.5]:

The minimum slope for adequate drainage shall comply with the Table below, except where an alternative method is provided that prevents the accumulation or pooling of water deeper than 1/8-inch 20 minutes after the cessation of the addition of water to the deck. Maximum slope for decks, other than wood, shall not exceed 1/2-inch per foot. Maximum slope for wood/plastic decks shall not exceed 1/4-inch per foot.

SURFACE	MINIMUM DRAINAGE SLOPE (INCH PER FOOT)
Carpet	1/2
Exposed Aggregate	1/4
Texted, hand-finished concrete	1/8
Travertine/brick-set pavers	1/8
Wood	1/8
Wood/plastic composite	1/8

Suction Entrapment Avoidance

Suction entrapment avoidance for pools and spas shall be provided in accordance with APSP-7. [310.1]

On-Ground Storable (Permanent or Portable) Swimming Pools

On-ground storable swimming pools shall be installed in accordance with the manufacturer's installation instructions. [701.5]

Ladders and Stairs [702]:

Ladders shall have a physical barrier which prevents children from swimming behind or through the ladder riser opening unless the manufacturer provides a certification statement that such ladder complies with the entrapment test requirements of APSP-4. [702.2.1]

Decks [703]:

Decks provided by the pool manufacturer shall be installed in accordance with the manufacturer's installation instructions. Any deck fabricated on-site shall meet the requirements of the 2015 International Residential Code (IRC). [703.1]

The top surface of cantilevered decks shall not be located more than 1-inch higher than the top of the pool wall. The top surface of non-cantilevered decks shall not be higher than the top of the pool wall. [703.2]

Where the deck extends inside the top rail of the pool, it shall be limited to not more than 3-inches beyond the inside of such rail and shall have a smooth finish. [703.4]

Walk-around decks shall have a minimum of 15-inch wide level surface as measured from the inside edge of the pool top rail. [703.6]

Circulation System [704.1]:

The circulation system and all of its components and related equipment shall be installed so that such items may not be used by children as a means of access to the pool.

Pumps shall be listed in accordance with UL 1081. [704.7]

Safety Signs [705]:

Manufacturer's safety and instruction signs shall be posted prior to final inspection. [705.1] Ladders shall have safety signage which states "No Diving", instructions for removing/securing ladder when not in use, and various entrapment warnings. [705.2]

In-Ground Swimming Pools

The structural design of in-ground swimming pools shall be in accordance with the 2015 International Residential Code (IRC). [802.2] Diving water envelopes, walls, offset ledges, pool floor slopes and transitions shall comply with Chapter 8 of the 2015 International Swimming Pool & Spa Code (ISPSC).

Diving Equipment [808]:

Manufactured and fabricated diving equipment shall be installed in accordance with the manufacturer's installation instructions [808.3] and may not be installed on Type-O pools [808.1].

Where a pool is designed for use with diving equipment, the location of features such as steps, stairs, ladders, underwater benches, special features and other accessory items, shall be located outside of the minimum diving water envelope. [808.7]

Stationary diving platforms and diving rocks built on-site shall be permitted to be flush with the pool wall, provided that the width, length and depth of the minimum required diving envelope is met at the pool wall. [808.8] The height of stationary diving platforms and diving rocks built on-site above the design waterline shall not exceed the dimensions in the following Table.

Pool Type	Height (inches)
I	42
II	42
III	50
IV	60
V	69

Special Features [809]:

Slides shall be installed in accordance with the manufacturer’s installation instructions. [809.1]

Pools shall have a mean of entry and exit in all shallow areas where the shallowest design water depth exceeds 24-inches and shall be located on the shallow side of the first slope change. [809.2]

A means of entry and exit shall be provided where water depth in the deep area of the pool exceeds 5-feet. [809.3] Pools over 30-feet in width shall have an entry and exit on both sides of the deep area.

[809.4]

Stairs into the shallow end of the pool and recessed stair shall comply with the design requirements of Section 809.5.

Beach and sloping entries, used as a pool entrance, shall not exceed 1-unit vertical in 7 units horizontal. [809.6]

The horizontal surfaces of underwater seats, benches and swimouts shall not be greater than 20-inches below the design waterline. [809.9]

Circulation Systems [810]:

The circulation system equipment shall be sized to provide a turnover of the pool water not less than once every 12 hours.

Safety Features [811]:

A rope or float assembly shall be installed across the width of the pool not less than 1-foot nor greater than 2-foot from the first slope break of the pool. Rope anchoring devices shall be permanently attached to the pool wall, coping or deck. Rope ends shall be equipped with a device to allow the rope to be disconnected from the anchoring devices. [811.1]

Permanent Spas and Exercise Spas

Spas and exercise spas shall comply with the manufacturer’s installation and safety instructions. [902.1]

Structure and Design [503]:

The maximum water depth, measured from the design waterline, shall be 48-inches for spas and 6-feet 6-inches for exercise spas. [503.1] Where multilevel seating is provided, the water depth of any seat or sitting bench shall not be more than 28-inches (when measured to the lowest measurable point) below the design waterline. [503.2] The slope of the floor shall not exceed 1:12 and, where multilevel seating is provided, the change in depth shall be indicated. [503.3]

Return and Suction Fittings [505]:

Return fittings shall be provided and arranged to facilitate a uniform circulation of water. [505.1] Suction fittings shall be listed and labeled in accordance with APSP 16. [505.2.1] Outlets and submerged vacuum fittings shall comply with Suction Entrapment Avoidance requirements of Section 310. [505.2]

Heater and Temperature Requirements [506]:

Water temperature controls shall comply with UL 873 or UL 372 and temperature at the heater return outlet shall not exceed 140°F.

Portable Spas and Exercise Spas

Factory-built portable spas and exercise spas shall be listed and labeled in compliance with UL 1563 or CSA C22.2 No. 218.10 and installed per the manufacturer's instructions. [1001.4/1001.3]

Permit Application Submittals

Site plan and fence details are required to be submitted when applying for a pool and fence permit. The site plan must include the fence and pool in reference to the house and property lines (see example on next page). This shall indicate the setbacks of the fence, if any, and pool from the property lines. Any misrepresentation will be handled by our Zoning and Building Department and may impose violations, fines and the removal of such installed structures.

Fence details including the size, measurements and materials of the fence or barrier shall be included when applying for a permit. If fence has not been purchased or selected at time of permit, processing may be delayed or rejected. **Note: Check with contractors that they are installing a barrier in compliance with the 2015 International Swimming Pool & Spa Code.**

If a contractor is installing a fence, please supply contractor's name, address and phone number.

Pool manufacturer details, as well as, pump specifications shall be submitted when applying. See the last page in this packet for a helpful checklist.

Once one has applied and paid for the permit, it will undergo the approval process. The zoning and building departments shall have 15 days to review each application and contact the owner or agent with any questions/concerns. When the permit is approved, it will be mailed to the applicant's house. Please post such permit in a window/door visible from the street during the construction project.

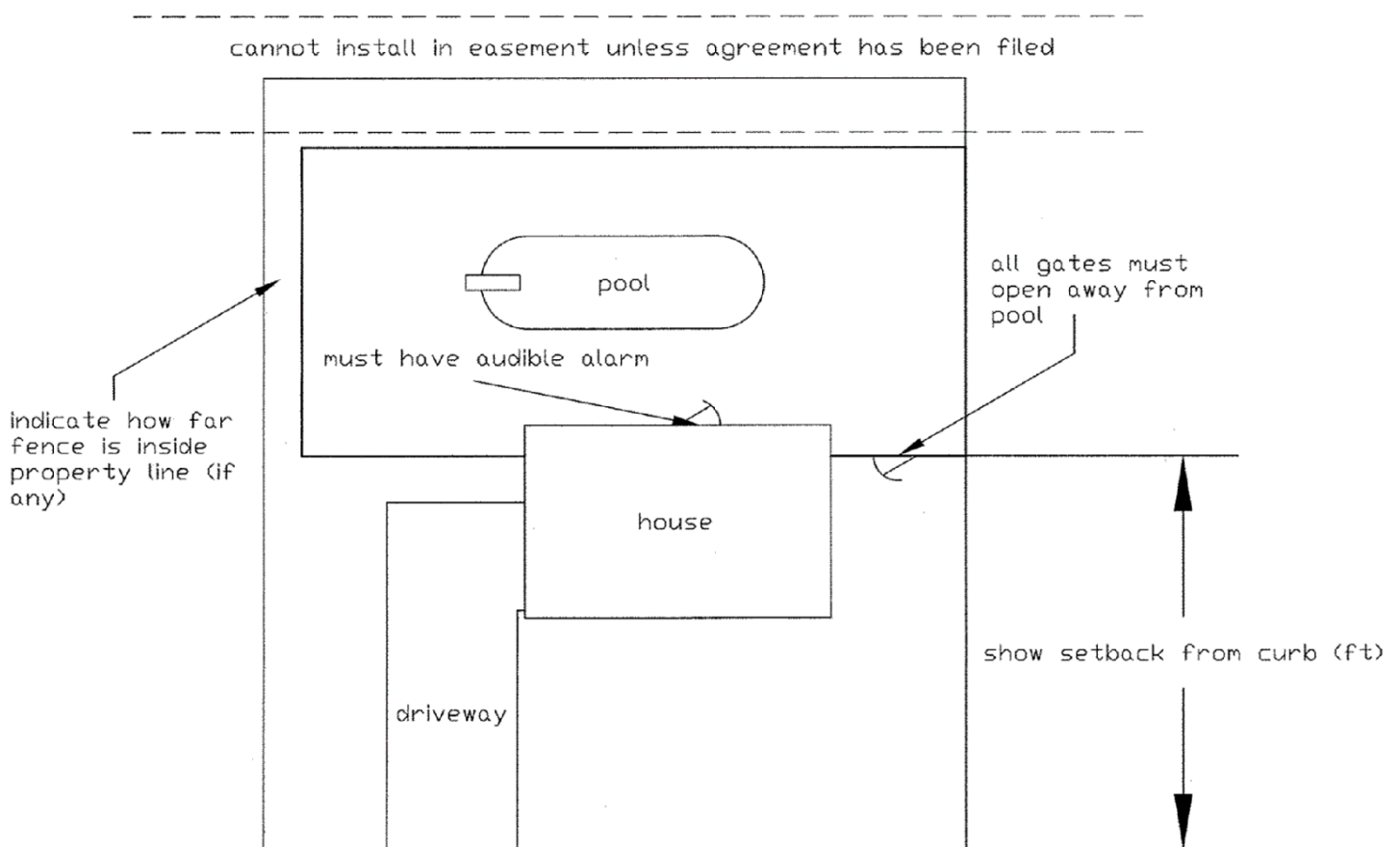

Example of Plot Plan

The following list includes applicable permits:

- Above-ground / in-ground pool permit
- Electrical permit
- Mechanical permit if installing gas heater

- d. State surcharge & occupancy fee
- e. Fence permit

Filtering systems must be installed at least 5' from any side or rear property line.

All water bearing sides of pool shall be a minimum of 10' from any side or rear property line and 5' from any structure. Any attached deck or platform shall be at least 5' from any property line. NOTE: NO POOL MAY BE INSTALLED IN THE LEGAL FRONT YARD. If a property is located on a corner, front yard setbacks occur for any property line abutting a street.

All electrical installations shall be installed as per the current National Electrical Code standards with ground-fault circuitry and shall be inspected by an approved inspection agency. The list will be provided with your application.

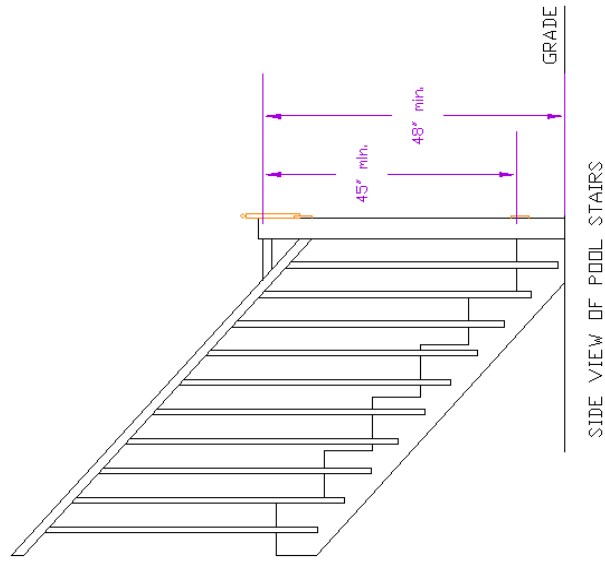

2015 INTERNATIONAL SWIMMING POOL & SPA CODE.
 * WHERE BARRIER IS COMPOSED OF HORIZONTAL AND VERTICAL MEMBERS AND THE DISTANCE BETWEEN THE TOPS OF THE HORIZONTALS IS LESS THAN 45 INCHES, THE HORIZONTAL MEMBERS SHALL BE LOCATED ON THE SWIMMING POOL SIDE OF THE FENCE AND SPACING SHALL NOT EXCEED 1-3/4 INCHES.
 * WHERE BARRIER IS COMPOSED OF HORIZONTAL AND VERTICAL MEMBERS AND THE DISTANCE BETWEEN THE TOPS OF THE HORIZONTALS IS 45 INCHES OR MORE, SPACING BETWEEN VERTICAL MEMBERS SHALL NOT EXCEED 4 INCHES.
 * ACCESS GATES SHALL BE EQUIPPED TO ACCOMMODATE A LOCKING DEVICE. PEDESTRIAN ACCESS GATES SHALL OPEN OUTWARD AWAY FROM POOL AND SHALL BE SELF-CLOSING AND HAVE A SELF-LATCHING DEVICE. THE RELEASE MECHANISM SHALL BE LOCATED NOT LESS THAN 54 INCHES FROM THE BOTTOM OF THE GATE.

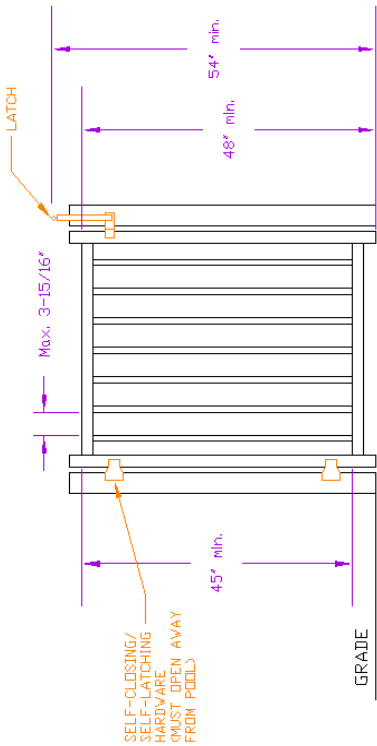

OPTION 1: WHEN THERE IS 45' BETWEEN TOPS OF HORIZONTALS

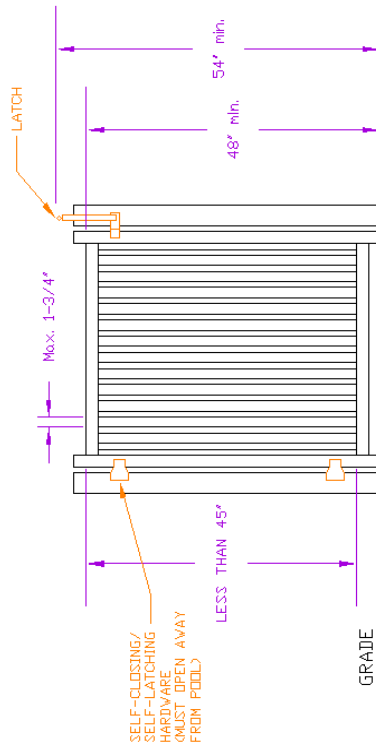

OPTION 2: WHEN THERE IS LESS THAN 45' BETWEEN TOPS OF HORIZONTALS

POOL DECK ACCESS GATE SAMPLE DETAILS

SWIMMING POOL AND SPA APPLICATION CHECKLIST

Municipality: Palmer Township

Date: _____

Site Address: _____

Applicant Name: _____

Phone: _____

Contractor Name: _____

Phone: _____

Type of Pool: Above-ground In-ground Temporary / Seasonal Spa
 Residential Commercial

If above ground pool will be constructed into the slope of the property, manufacturer's specifications must be submitted to show that the pool can be partially buried.

Barrier: Pool wall 48 inches or higher Installing fence 48 inches or higher

Fence Gates: Self closing & latching & locking Swing in direction of egress

Include Fence and Gate details on plans

Pool is separated from house with fence full around. No access from house to pool area.

Ladders: Secured, lockable or removable or surrounded by a code compliant barrier.

Door Alarms If the house is used as part of the barrier all doors must be alarmed per code. (UL 2017)

Pool pump All specifications included with permit. (UL listed pump)

Electrical service Verify that there are no overhead electrical lines

Energy Will the pool be heated? If so, provide manufacturer's specification sheet.

Heated pools with vapor retardant pool cover

Entrapment Provide entrapment protection details

Plans Provide 2 sets of complete plans with all of the above information

Note: (Pool diagram showing size and type of pool, pool pump specifications, ladder type, fence style and self-closing and self-latching gates) All pool equipment specifications must be submitted.