

# PALMER TOWNSHIP, PENNSYLVANIA

## Typical Deck Details

Based on the 2015 International Residential Code  
and Pennsylvania Uniform Construction Code Amendments  
(Designed and Printed March 2019)

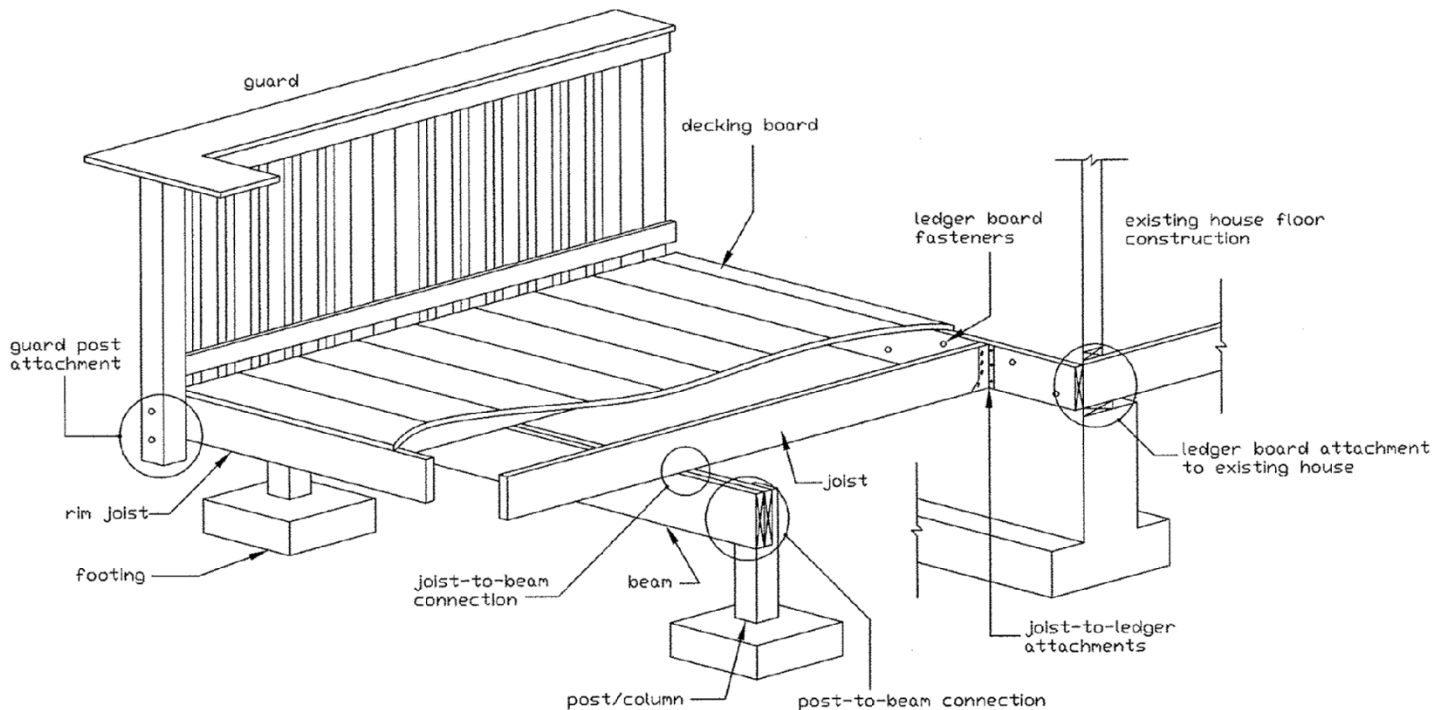

### CONTENTS

General Information.....	2	Ledger Board Fastener Spacing.....	7
Footings .....	3	Lateral Load Connection.....	8
Joist Sizing and Span.....	4	Framing at Cantilevered Floor System.....	9
Beam Sizing and Spans.....	4	Lateral Restraints at Supports.....	9
Deck Post Allowable Heights.....	5	Guard Requirements.....	10
Deck Post-to-Beam Connections.....	6	Guard Post Installation.....	10
Deck Post-to-Footing Connections.....	6	Stair Handrail Requirements.....	11
Bracing.....	6	Decking Requirements.....	11
Ledger Attachment.....	6	Application and Process for Permit.....	12

**THE USE OF THIS PACKAGE APPLIES ONLY TO SINGLE LEVEL, RESIDENTIAL DECKS SUPPORTING A TOTAL LOAD OF 50 LBS/SQFT. CONCENTRATED LOADS, SUCH AS HOT TUBS, POOLS, OUTDOOR KITCHENS, ETC. MUST BE EVALUATED/APPROVED BY A REGISTERED DESIGN PROFESSIONAL. DECKS MUST BE CONSTRUCTED IN CONFORMANCE WITH THE 2015 INTERNATIONAL RESIDENTIAL CODE AND THE PENNSYLVANIA UNIFORM CONSTRUCTION CODE, WHICH SUPERCEDES ANY DISPREPANCY LOCATED HEREIN. \*CODE REFERENCES ARE [BRACKETED]\***



## **GENERAL INFORMATION**

1. Definition: Deck – An exterior floor system supported on at least two opposing sides by an adjoining structure and/or posts, piers, or other independent supports.
2. All wood in contact with the ground, embedded in concrete in direct contact with the ground or embedded in concrete exposed to the weather that supports permanent structures intended for human occupancy shall be approved pressure-preservative treated wood suitable for ground contact use. [R317.1.2]
3. Wood/plastic composites used in deck boards, stair treads, handrails and guardrail systems shall comply with the provisions of ASTM D 7032 and shall be installed per the manufacturer's instructions. [R507.3]
4. Lag screws, bolts and washers shall be hot-dipped galvanized or stainless steel.
5. All screws and nails shall be hot-dipped zinc-coated galvanized steel, stainless steel, silicon bronze or copper. All steel bolts shall be of one-half-inch diameter or larger. [R317.3]
6. To resist corrosion, fasteners shall meet the requirements of ASTM A 153. [R317.3]
7. All connectors (post anchors, joist hangers, post-to-beam connectors) shall be galvanized or stainless steel. [R317.3.1]
8. Where exterior decks attach to a wall or floor assembly of wood-frame construction, corrosion-resistant metal flashing or approved non-metallic material shall be installed to prevent water from contacting the house band joist. [R703.4/R507.2 footnote a]  
\*Bare aluminum shall not be used in direct contact with lumber treated with preservatives that contain copper (such as ACQ, Copper Azole or ACZA)\*
9. All of the following inspections are required during construction of deck:
  - Footing inspections are required before the concrete is poured. All holes must be cleaned and free from loose dirt.
  - Framing inspections must be completed before the decking may be attached, unless otherwise noted.
  - Final inspection shall be scheduled when all construction of the deck has been completed.
  - **NOTE: ALL INSPECTIONS ARE MANDATORY BY LAW. FAILURE TO OBTAIN THE INSPECTIONS MAY CAUSE VIOLATIONS AND FINES.**
10. It shall be the duty of the permit holder or their agent to notify the building official that such work is ready for inspection. It shall be the duty of the person requesting any inspections required by this code to provide access and means for inspection of such work.
11. All inspections must be made at least 24 hours in advance. All construction documents shall be on the jobsite and provided to inspector upon request. You may schedule an appointment for inspection by calling Palmer Township's Offices at (610) 253-7191 Monday thru Friday 8:30a.m. – 4:30p.m.
12. Decks may not be occupied until all inspections have been completed and a final approval (in the form of a certificate of occupancy) has been issued by the Building Code Official.

## FOOTINGS

All footers must be a minimum of 36" below grade and bear on undisturbed, natural soil. Deck footings closer than 5'-0" to an existing exterior house wall must bear at the same elevation as the existing footer of the house. **The size of footings supporting piers and columns shall be based on tributary load and the allowable soil pressure of 1500 psf** (unless soil test data is provided). [R403.1.1] Do not construct footings over utility lines or enclosed meters - Call 811 before you dig.

To determine pier minimum width, first calculate tributary area supported by each column/post (see Figure 1).

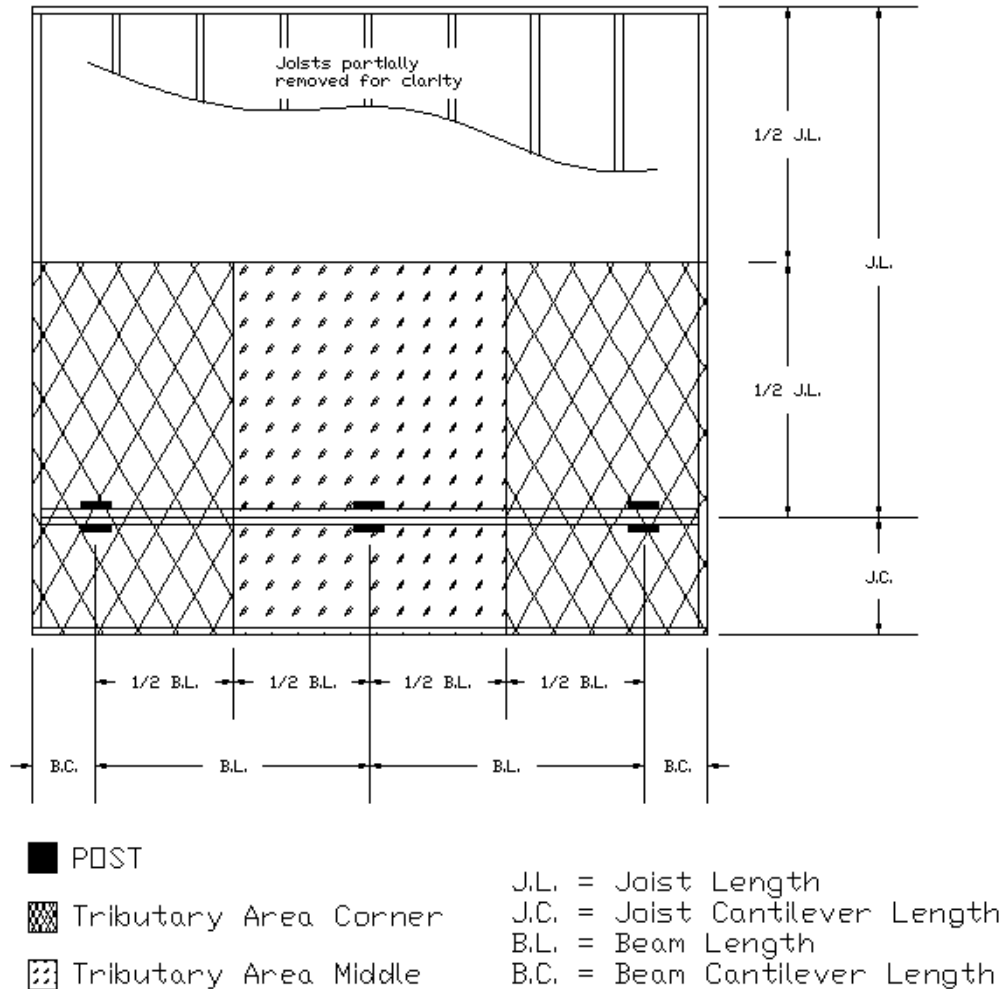

Figure 1

Then, the tributary area is multiplied by 50 psf (40 psf live load + 10 psf dead load). The result is the "Tributary Load". Once the tributary load is found, you may use one of the equations below to find the minimum round or square footing size.

Round footing (inches):  $D = 12\sqrt{\frac{4R}{(\text{soil capacity})\pi}}$

Square footing (inches):  $B = 12\sqrt{\frac{R}{(\text{soil capacity})}}$

Footing thickness (inches):  $T \geq P; T \geq \frac{(B \text{ or } D) - 5.5}{2}$

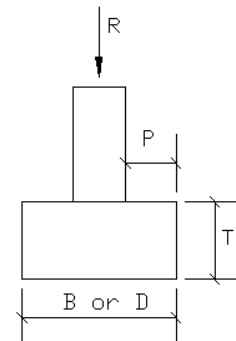

## JOIST SIZING AND SPAN

Maximum allowable spans for wood deck joists shall be in accordance with Table 1 and the Figure 2 below. Deck joists are permitted to cantilever not greater than one-fourth of the actual, adjacent span. [R507.5] Joist framing into the side of a ledger board or beam shall be supported by approved joist hangers. Joists bearing on a beam shall be connected to the beam to resist lateral displacement. [R507.7]

**TABLE 1**  
**DECK JOIST SPANS FOR COMMON LUMBER SPECIES<sup>f</sup> (ft. - in.)**

SPECIES <sup>a</sup>	SIZE	SPACING OF DECK JOISTS WITH NO CANTILEVER <sup>b</sup>			SPACING OF DECK JOISTS WITH CANTILEVERS <sup>c</sup>		
		(inches)			(inches)		
		12	16	24	12	16	24
Southern pine	2 x 6	9-11	9-0	7-7	6-8	6-8	6-8
	2 x 8	13-1	11-10	9-8	10-1	10-1	9-8
	2 x 10	16-2	14-0	11-5	14-6	14-0	11-5
	2 x 12	18-0	16-6	13-6	18-0	16-6	13-6
Douglas fir-larch <sup>d</sup> , hem-fir <sup>d</sup> spruce-pine-fir <sup>d</sup>	2 x 6	9-6	8-8	7-2	6-3	6-3	6-3
	2 x 8	12-6	11-1	9-1	9-5	9-5	9-1
	2 x 10	15-8	13-7	11-1	13-7	13-7	11-1
	2 x 12	18-0	15-9	12-10	18-0	15-9	12-10
Redwood, western cedars, ponderosa pine <sup>e</sup> , red pine <sup>e</sup>	2 x 6	8-10	8-0	7-0	5-7	5-7	5-7
	2 x 8	11-8	10-7	8-8	8-6	8-6	8-6
	2 x 10	14-11	13-0	10-7	12-3	12-3	10-7
	2 x 12	17-5	15-1	12-4	16-5	15-1	12-4

- No. 2 grade with wet service factor.
- Ground snow load, live load = 40 psf, dead load = 10 psf,  $L/\Delta = 360$
- Ground snow load, live load = 40 psf, dead load = 10 psf,  $L/\Delta = 360$  at main span,  $L/\Delta = 180$  at cantilever with a 220-pound point load applied to end.
- Includes incising factor.
- Northern species with no incising factor.
- Cantilevered spans not exceeding the nominal depth of the joist are permitted.

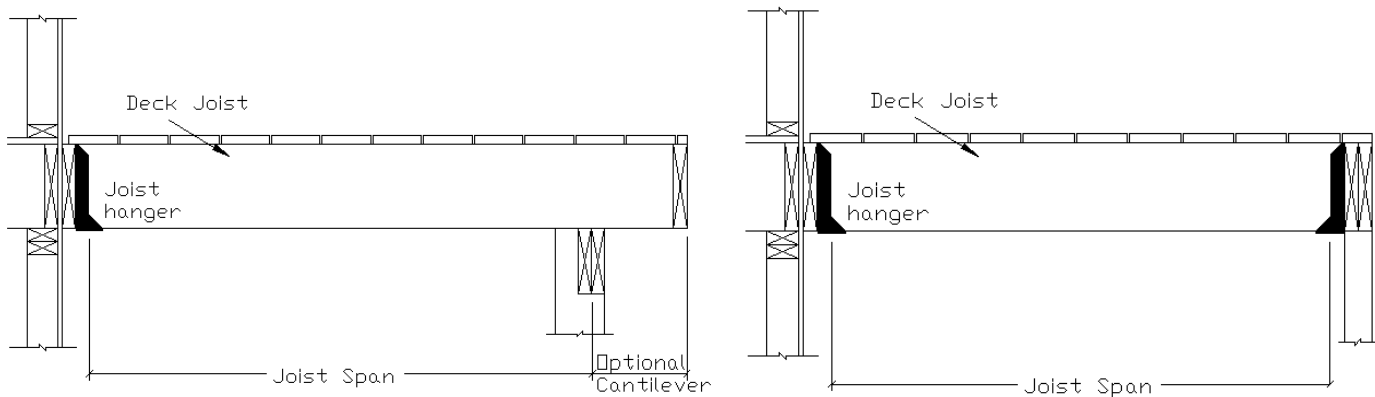

Figure 2

## BEAM SIZE AND ASSEMBLY REQUIREMENTS

Maximum allowable spans for wood deck beams shall be in accordance with Table 2. Beam spans are measured to the centerline of each post. Beam plies shall be fastened with two rows of 10d nails minimum at 16 inches on center along each edge. Beams shall be permitted to cantilever at each end up to one-fourth of the actual beam span. Splices of multi-span beams shall be located at interior post locations. [R507.5/2018 IRC Table 507.5] The ends of each beam shall have not less than 1.5 inches of bearing on wood or metal and not less than 3 inches on concrete or masonry. [R507.7] Beams may not be supported on deck ledgers or band joists. [R507.2.1] If using engineered lumber, an engineer's seal is required upon submission. [R301.1.3]

**TABLE 2**  
**DECK BEAM SPAN LENGTHS<sup>a, b, g</sup> (feet - inches)**

SPECIES <sup>c</sup>	SIZE <sup>d</sup>	DECK JOIST SPAN LESS THAN OR EQUAL TO:						
		(feet)						
		6	8	10	12	14	16	18
Southern pine	1 - 2 x 6	4-11	4-0	3-7	3-3	3-0	2-10	2-8
	1 - 2 x 8	5-11	5-1	4-7	4-2	2-10	3-7	3-5
	1 - 2 x 10	7-0	6-0	5-5	4-11	4-7	4-3	4-0
	1 - 2 x 12	8-3	7-1	6-4	5-10	5-5	5-0	4-9
	2 - 2 x 6	6-11	5-11	5-4	4-10	4-6	4-3	4-0
	2 - 2 x 8	8-9	7-7	6-9	6-2	5-9	5-4	5-0
	2 - 2 x 10	10-4	9-0	8-0	7-4	6-9	6-4	6-0
	2 - 2 x 12	12-2	10-7	9-5	8-7	8-0	7-6	7-0
	3 - 2 x 6	8-2	7-5	6-8	6-1	5-8	5-3	5-0
	3 - 2 x 8	10-10	9-6	8-6	7-9	7-2	6-8	6-4
	3 - 2 x 10	13-0	11-3	10-0	9-2	8-6	7-11	7-6
	3 - 2 x 12	15-3	13-3	11-10	10-9	10-0	9-4	8-10
Douglas fir-larch <sup>e</sup> , hem-fir <sup>e</sup> , spruce-pine-fir <sup>e</sup> , redwood, western cedars, ponderosa pine <sup>f</sup> , red pine <sup>f</sup>	3 x 6 or 2 - 2 x 6	5-5	4-8	4-2	3-10	3-6	3-1	2-9
	3 x 8 or 2 - 2 x 8	6-10	5-11	5-4	4-10	4-6	4-1	3-8
	3 x 10 or 2 - 2 x 10	8-4	7-3	6-6	5-11	5-6	5-1	4-8
	3 x 12 or 2 - 2 x 12	9-8	8-5	7-6	6-10	6-4	5-11	5-7
	4 x 6	6-5	5-6	4-11	4-6	4-2	3-11	3-8
	4 x 8	8-5	7-3	6-6	5-11	5-6	5-2	4-10
	4 x 10	9-11	8-7	7-8	7-0	6-6	6-1	5-8
	4 x 12	11-5	9-11	8-10	8-1	7-6	7-0	6-7
	3 - 2 x 6	7-4	6-8	6-0	5-6	5-1	4-9	4-6
	3 - 2 x 8	9-8	8-6	7-7	6-11	6-5	6-0	5-8
	3 - 2 x 10	12-0	10-5	9-4	8-6	7-10	7-4	6-11
	3 - 2 x 12	13-11	12-1	10-9	9-10	9-1	8-6	8-1

- a. Ground snow load, live load = 40 psf, dead load = 10 psf, L/Δ = 360 at main span, L/Δ = 180 at cantilever with a 220-pound point load applied to end.
- b. Beams supporting deck joists from one side only.
- c. No. 2 grade, wet service factor.
- d. Beam depth shall be greater than or equal to depth of joists with a flush beam condition.
- e. Includes incising factor.
- f. Northern species. Incising factor not included.
- g. Beam cantilevers are limited to the adjacent beam's span divided by 4.

### **DECK POST ALLOWABLE HEIGHTS**

For single-level wood-framed decks, the deck post size shall be in accordance with Table 3 below. [R507.8]

**TABLE 3**  
**DECK POST HEIGHT<sup>a</sup>**

DECK POST SIZE	MAXIMUM HEIGHT <sup>a</sup>
4 x 4	8'
4 x 6	8'
6 x 6	14'

- a. Measured to the underside of the beam.

## **DECK POST-TO-BEAM CONNECTIONS**

Deck post-to-beam connections shall be by either approved post cap or the notching of a 6x6 post to allow the beam to rest directly on the post. The remaining portion of the 6x6 post shall be minimum 2-1/2" and shall use through-bolts with washers and nuts. [R507.7.1] See Figure 4 below.

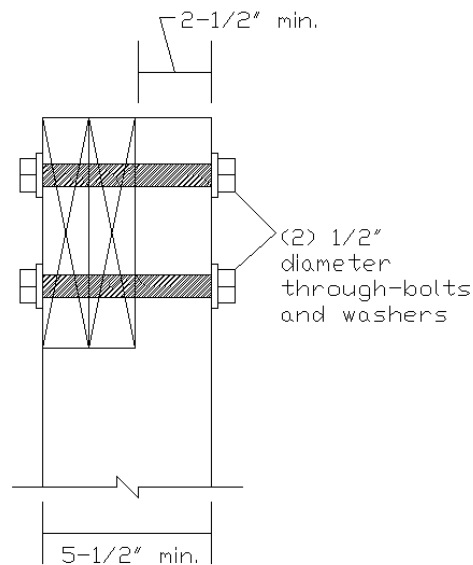

Figure 3

## **DECK POST-TO-FOOTING CONNECTIONS**

Deck posts shall bear onto footings and be restrained to prevent lateral displacement at the bottom support. This may be achieved by using an approved manufactured connector or with a minimum 12-inch post embedment into concrete or soil surround pier.

## **BRACING**

Exterior landings, decks, and stairs shall be positively anchored to the primary structure to resist both vertical and lateral forces or shall be designed to be self-supporting. Attachment shall not be accomplished by use of toenails or nails subject to withdrawal.

Freestanding decks shall require diagonal bracing both parallel and perpendicular to the beam at each post. If it is attached to the house in accordance with the information contained herein, then the bracing perpendicular to the house shall not be required.

## **LEDGER ATTACHMENT**

The deck ledger shall be minimum 2-inch by 8-inch nominal pressure-preservative-treated southern pine, incised pressure-preservative-treated Hem-fir, or approved, naturally durable, No. 2 grade or better lumber. [R507.2.1] For any other grade or species, or other connection details or loading conditions, the deck ledger connection shall be approved by a registered design professional. [R507.2]

Deck ledgers shall not support concentrated loads from beams or girders, nor shall be supported on stone or masonry veneer. [R507.2.1]

The band joist shall be minimum 2-inch-nominal, solid-sawn, spruce-pine-fir lumber or a minimum 1-inch by 9-1/2-inch dimensional, Douglas fir, laminated veneer lumber. Band joists shall be fully supported by a wall or sill plate below. [R507.2.2]

The connection between a deck ledger and band joist shall be constructed with 1/2-inch lag screws or bolts with washers in accordance with Table 4. Lag screws, bolts and washers shall be hot-dipped galvanized or stainless steel. The removal of siding and installation of flashing is required between the house and the ledger. NOTE: YOU MAY NOT ATTACH LEDGER BOARDS TO EXISTING CANTILEVERS, OPEN WEB TRUSSES OR STONE OR MASONRY VENEER. If these conditions occur, the deck must be freestanding.

**TABLE 4**  
**DECK LEDGER CONNECTION TO BAND JOIST<sup>a, b</sup>**  
 (Deck live load = 40 psf, deck dead load = 10 psf, snow load ≤ 40 psf)

CONNECTION DETAILS	JOIST SPAN						
	6' and less	6'1" to 8'	8'1" to 10'	10'-1" to 12'	12'1" to 14'	14'1" to 16'	16'1" to 18'
	On-center spacing of fasteners						
1/2-inch diameter lag screw with 1/2-inch maximum sheathing <sup>c, d</sup>	30	23	18	15	13	11	10
1/2-inch diameter bolt with 1/2-inch maximum sheathing <sup>d</sup>	36	36	34	29	24	21	19
1/2-inch diameter bolt with 1-inch maximum sheathing <sup>e</sup>	36	36	29	24	21	18	16

- a. Ledgers shall be flashed in accordance with Section R703.4 to prevent water from contacting the house band joist.
- b. Snow load shall not be assumed to act concurrently with live load.
- c. The tip of the lag screw shall fully extend beyond the inside face of the band joist.
- d. Sheathing shall be wood structural panel or solid sawn lumber.
- e. Sheathing shall be permitted to be wood structural panel, gypsum board, fiberboard, lumber or foam sheathing. Up to 1/2-inch thickness of stacked washers shall be permitted to substitute for up to 1/2-inch of allowable sheathing thickness where combined with wood structural panel or lumber sheathing.

The placement of lag screws and bolts in ledgers shall be in accordance with Table 5 and Figure 8 below. [R507.2.3]

**TABLE 5**  
**PLACEMENT OF LAG SCREWS AND BOLTS IN DECK LEDGERS AND BAND JOISTS**  
**MINIMUM END AND EDGE DISTANCES AND SPACING BETWEEN ROWS**

	TOP EDGE	BOTTOM EDGE	ENDS	ROW SPACING
Ledger <sup>a</sup>	2 inches <sup>d</sup>	3/4 inch	2 inches <sup>b</sup>	1-5/8 inches <sup>b</sup>
Band Joist <sup>c</sup>	3/4 inch	2 inches	2 inches <sup>b</sup>	1-5/8 inches <sup>b</sup>

- a. Lag screws or bolts shall be staggered from the top to the bottom along the horizontal run of the deck ledger in accordance with Figure R507.2.1(1).
- b. Maximum 5 inches.
- c. For engineered rim joists, the manufacturer's recommendations shall govern.
- d. The minimum distance from bottom row of lag screws or bolts to the edge of the ledger shall be in accordance with Figure R507.2.1(1).

\*Distance may be reduced to 4.5" if lag screws are used or bolt spacing is reduced to that of lag screws to attach 2x8 ledgers to 2x8 band joists.

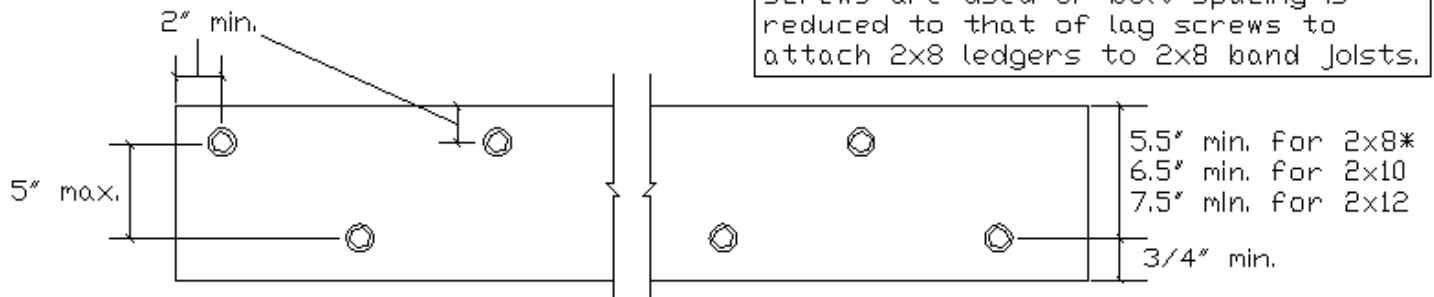

Figure 4

Where supported by attachment to an exterior wall, decks shall be positively anchored to the primary structure and designed for both vertical and lateral loads. [R507.1] Hold-down tension devices (such as the Simpson Strong-tie DTT2Z) shall be installed in not less than two locations per deck, within 24-inches of each end of the deck and each device shall have an allowable stress design capacity of not less than 1500 pounds (see example in Figure 9). If hold-down tension devices (such as the Simpson Strong-tie DTT1Z) are used, the minimum allowable stress design capacity of each device shall be 750 pounds and be installed in not less than four locations per deck (see example in Figure 10). [R507.2.4] Refer to manufacturer's installation instructions for specific information.

Where positive attachment cannot be verified during inspection, decks shall be self-supporting/free standing. [R507.1] Note: Tension devices used with I-joists must be installed per I-joist's manufacturer's engineered installation instructions.

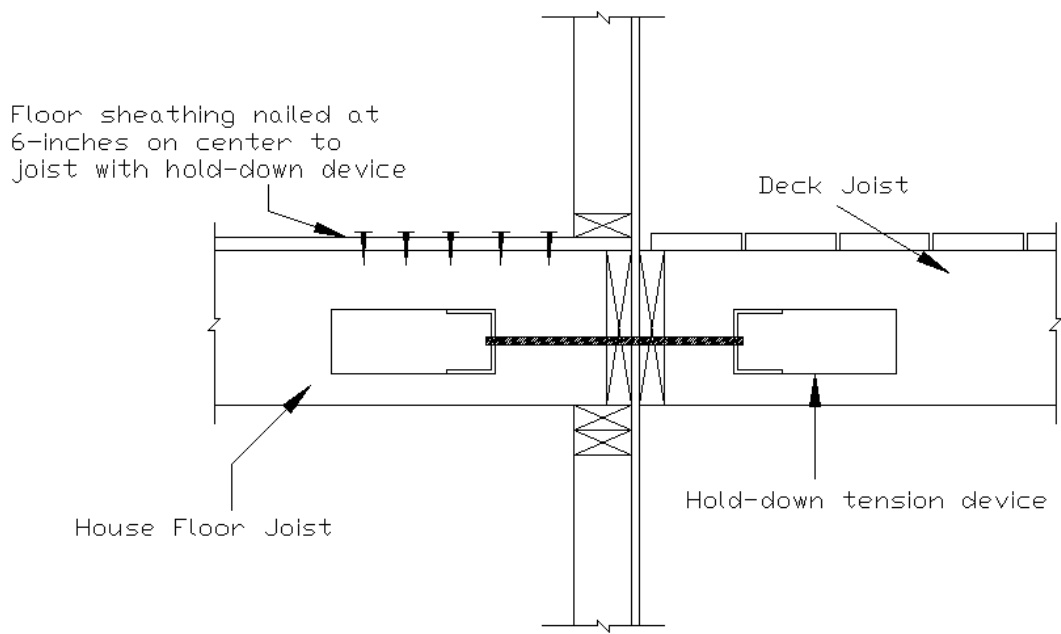

Figure 5



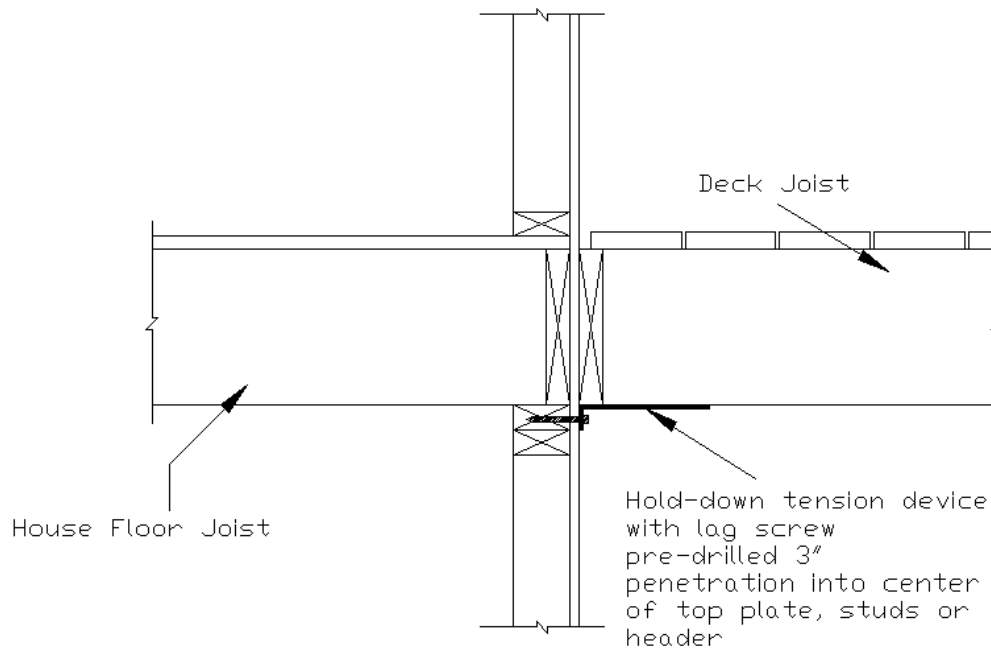

Figure 6

### **FRAMING AROUND A CANTILEVERED FLOOR SYSTEM**

Attaching the ledger to a house overhang, chimney or bay window shall be prohibited. Use an alternate deck framing plan to achieve structural stability without fastening to the projection (see Figure 11 for example). [R507.2.2] Girders supporting deck joists shall not be supported by deck ledgers or band joists. [R507.2.1]

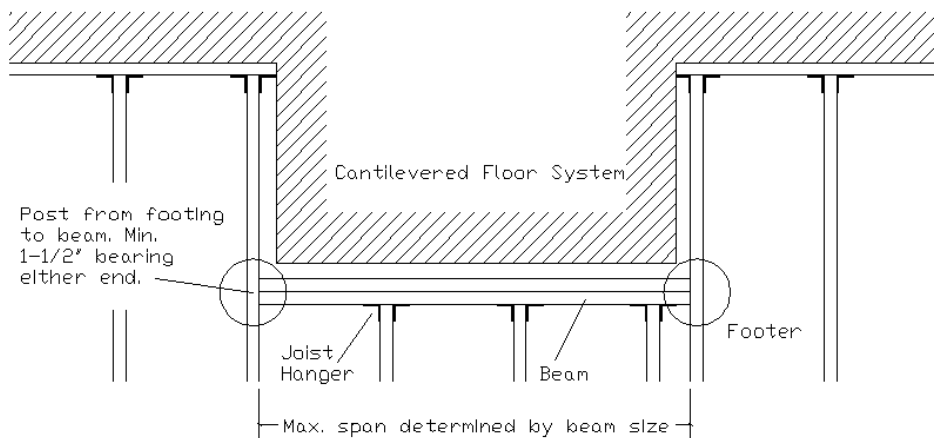

Figure 7

### **LATERAL RESTRAINTS AT SUPPORTS**

Bearing locations and joist ends shall be provided with lateral restraints to prevent rotation. This can be accomplished by use of joist hangers or blocking between joists at a depth of at least 60 percent of joist depth. If accomplished by rim board, use (3) 10d nails or (3) No. 10x3-inch long wood screws to attach rim joist into each floor joist (see Figure 12). [R507.5.1]

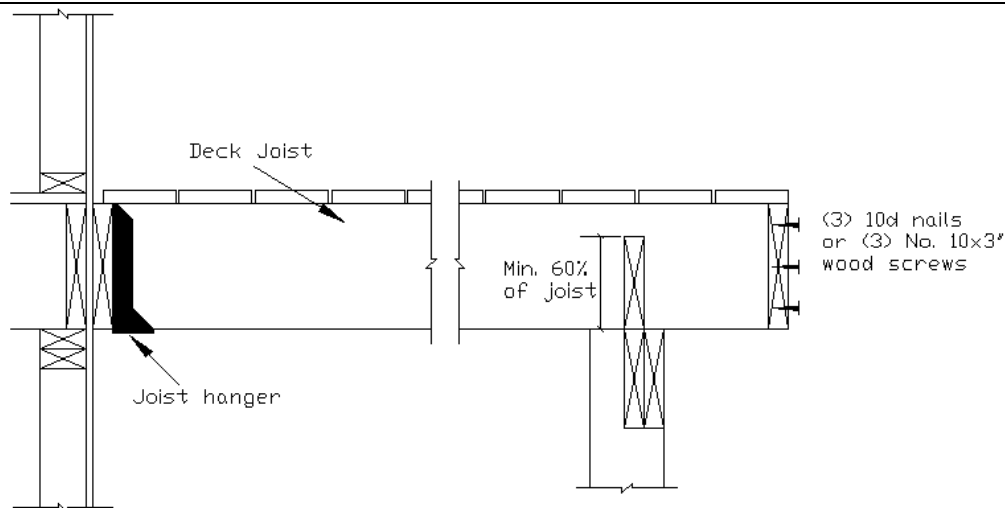

Figure 8

## **GUARD REQUIREMENTS**

Porches, balconies, ramps or raised floor surfaces located more than 30" above the floor or grade, within 36" horizontally to the edge of the open side, shall have guards not less than 36" in height. [R312.1.1/R312.1.2] Open sides of stairs with a total rise of more than 30" shall not have guards less than 34" measured vertically from the tread nosing. [R312.1.2 exception 1]

Required guards on open sides of stairways, raised floor areas, balconies and porches shall have intermediate rails or ornamental closures which do not allow the passage of a sphere 4" or more in diameter. [R312.1.3] Exceptions:

1. The triangular openings formed by the riser, tread and bottom rail at the open side of the stairway are permitted to be of such size that a 6" sphere cannot pass through.
2. Openings for required guards on the sides of stair treads shall not allow the passage of a sphere 4-3/8" in diameter.

The maximum riser height shall be 8-1/4" measured vertically between leading edges of adjacent treads. The minimum tread depth shall be 9" measured horizontally from beginning to end of tread. [PA UCC] Handrails may not be less than 34" nor greater than 38" above tread nosing and must be continuous throughout the run of stairs.

## **GUARD POST INSTALLATION**

Consideration must be taken to the installation techniques of guard posts. Guards and handrails shall be able to resist a live load of 200 psf as a single concentrated load applied in any direction at any point along the top. [R301.5] The International Code Council Evaluation Service Acceptance Criteria 273 for Handrails and Guards (AC273) places reasonable limits on tested assemblies. The maximum permissible deflection in AC273 for 36"-high guards is 3". Due to the large leverage arm of a guard post, and in order to achieve less than a 3-inch deflection at the top of a 36" rail, the post attachment at the deck must be capable of resisting a safety factor of 2.5 (or 500 lbs)! Virginia Tech's "*Design and Testing of Residential Deck Guard Rail Connections*" guide prescribes post connection details found to have met compliance of the 2015 International Residential Code (see Figure 13).

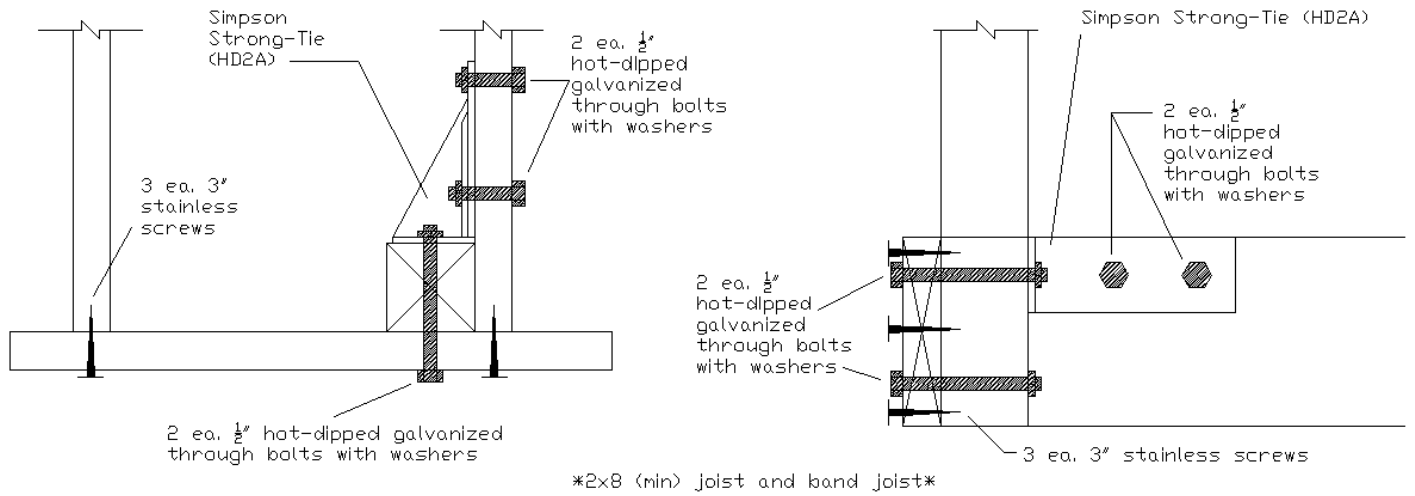

Figure 9

\*Note that to achieve code-compliance guard posts are not notched.\*

## **STAIR HANDRAIL REQUIREMENTS**

Handrails shall be provided on at least one side of each continuous run of treads or flight with four or more risers. Handrails shall be located between 34" and 38" measured vertically from the sloped plane adjoining tread nosing. It shall be continuous for the full length of the flight.

Handrail shall comply with one of the following options:

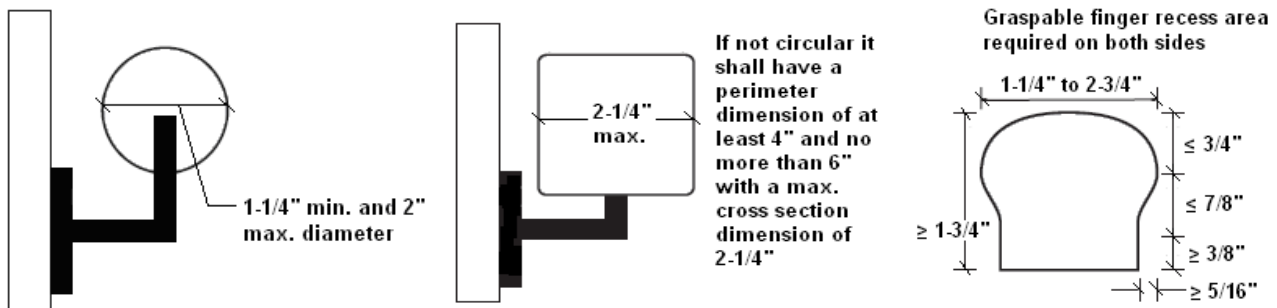

Figure 10

## **DECKING REQUIREMENTS**

Decking material shall be 2"x6" or 5/4" lumber or other approved composite matter. Any synthetic or composite material shall be approved by the building official, only after an ICC Evaluation Report of the particular product. The reports may be found at [http://www.icc-es.org/Evaluation\\_Reports/index.shtml](http://www.icc-es.org/Evaluation_Reports/index.shtml) by searching the manufacturer or product name. Decking shall not have a span that would compromise a 50 lb. per square foot load capacity.

## APPLICATION AND PROCESS FOR PERMIT

Any owner or authorized agent, who intends to construct a deck, or any other work regulated by the International Residential Code, shall first make application to the building official and obtain the required permit.

Applications are handled by Palmer Township's Permit Clerk at the Municipal Building between the hours 8:30a.m. and 4:30p.m. Monday thru Friday, unless otherwise posted. A total square footage of the proposed deck and the contractor's name (if any), address, and phone number will be required.

Submittals at the time of application shall include a framing/footer plan and a site plan. The site plan must include the deck in reference to the house and property lines. Any misrepresentation will be handled by our Zoning and Building Department and may impose violations, fines and the removal of such installed structures.

The framing plan shall include placement of footers, spans of joists, and size/span of girder beams. Step, railing and attachment details shall also be incorporated into the plans.

Once one has applied and paid for the permit, it will undergo the approval process. The zoning and building departments shall have 15 business days to review each application and contact the owner or agent with any questions/concerns. When the permit is approved, it will be mailed to the applicant's house. Please post such permit in a window/door visible from the street during the construction project.

Failure to obtain the required permit before the start of construction will be subjected to violations and fines of not more than \$1,000 per day as prescribed by law.

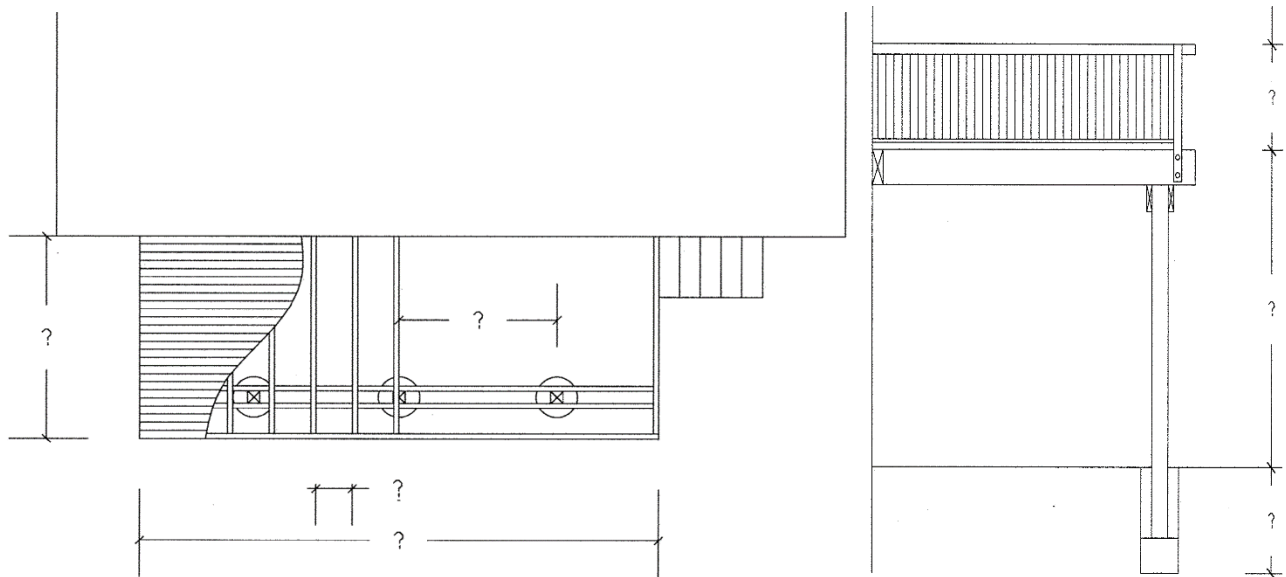

Figure 11